

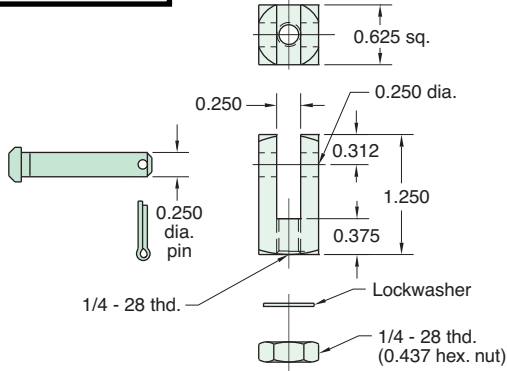

# 7/8" BORE MOUNTING BRACKETS

**15015**

Rod Clevis Assembly



**15018-1**

Foot Mounting Bracket

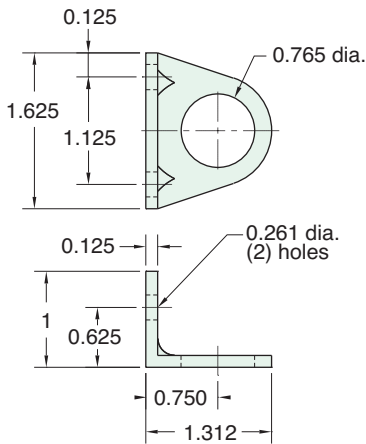

**CUSTOM**er  
solutions

If you need a product that fits your application perfectly, Clippard has the capability to design or modify one of its products to suit your exact needs. We understand that a standard catalog product may be close but not be exactly what you need. Let us know YOUR Need, and we will help to find YOUR Solution!

### Special Cylinders

Clippard produced the first rolled-construction cylinder in 1949. Since then, we have produced thousands of special configurations from cartridge designs to low break-away miniature cylinders.

